

TECHNICAL DATA SHEET

D - 900 -35 Z ASTRAGAL SCREW / WELD APPLICATION

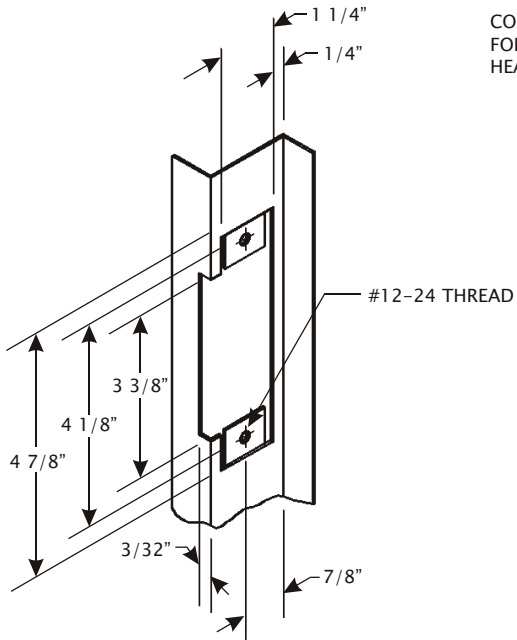

"U" STRIKE PREPARATION
ANSI 115.1

COUNTERSUNK
FOR #10 FLAT
HEAD SCREW

SEE STRIKE
PREPARATION
DETAIL

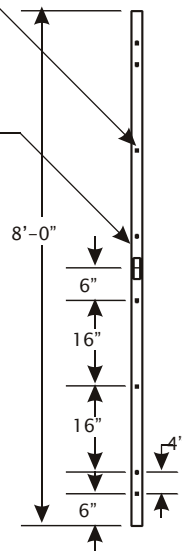

8'-0" ASTRAGAL CAN BE
CUT TO LENGTH TO
ACCOMMODATE 6'-8",
7'-0" AND 7'-2" DOORS,
REGARDLESS OF SWING
OR HANDING.

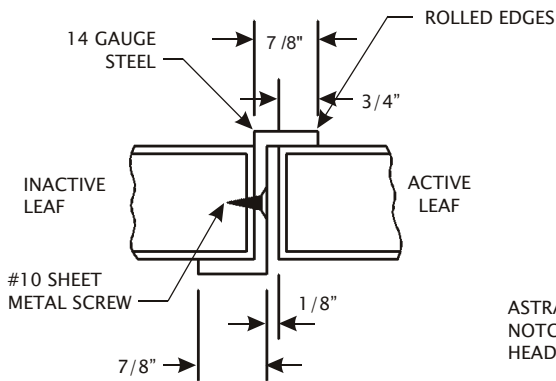

'Z' ASTRAGAL

NOTCH ASTRAGAL TO
CLEAR HEADER

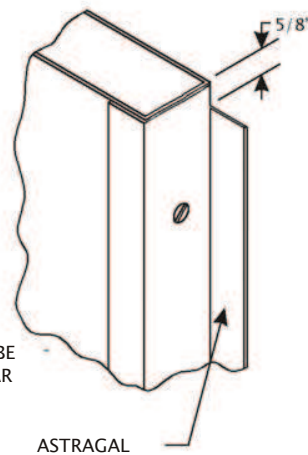

ASTRAGALS MUST BE
NOTCHED TO CLEAR
HEADER

Issue Date: January 2006

REVISED : 02/01/2009

